



Explorer D310





Depth Instrument

Installation and Operation Manual

NORTHSTAR

www.northstarnav.com

IMPORTANT SAFETY INFORMATION
Please read carefully before installation and use.

	This is the safety alert symbol. It is used to alert you to potential personal injury hazards. Obey all safety messages that follow this symbol to avoid possible injury or death.
	WARNING indicates a potentially hazardous situation which, if not avoided, could result in death or serious injury.
	CAUTION indicates a potentially hazardous situation which, if not avoided, could result in minor or moderate injury.
	CAUTION used without the safety alert symbol indicates a potentially hazardous situation which, if not avoided, may result in property damage.

DISCLAIMER: It is the owner's sole responsibility to install and use the instrument and transducers in a manner that will not cause accidents, personal injury or property damage. The user of this product is solely responsible for observing safe boating practices.

NAVICO HOLDING AS. AND ITS SUBSIDIARIES, BRANCHES AND AFFILIATES DISCLAIM ALL LIABILITY FOR ANY USE OF THIS PRODUCT IN A WAY THAT MAY CAUSE ACCIDENTS, DAMAGE OR THAT MAY VIOLATE THE LAW.

Governing Language: This statement, any instruction manuals, user guides and other information relating to the product (Documentation) may be translated to, or

has been translated from, another language (Translation). In the event of any conflict between any Translation of the Documentation, the English language version of the Documentation will be the official version of the Documentation.

This manual represents the Explorer D310 as at the time of printing. Navico Holding AS. and its subsidiaries, branches and affiliates reserve the right to make changes to specifications without notice.

Copyright © 2008 Navico Holding AS.
Northstar™ is a registered trademark of Navico Holding AS.

FCC Statement

Note: This equipment has been tested and found to comply with the limits for a Class B digital device, pursuant to Part 15 of the FCC Rules. These limits are designed to provide reasonable protection against harmful interference in a normal installation. This equipment generates, uses and can radiate radio frequency energy and, if not installed and used in accordance with the instructions, may cause harmful interference to radio communications. However, there is no guarantee that interference will not occur in a particular installation. If this equipment does cause harmful interference to radio or television reception, which can be determined by turning the equipment off and on, the user is encouraged to try to correct the interference by one or more of the following measures:

- Reorient or relocate the receiving antenna.
- Increase the separation between the equipment and receiver.
- Connect the equipment into an output on a circuit different from that to which the receiver is connected.
- Consult the dealer or an experienced technician for help.
- A shielded cable must be used when connecting a peripheral to the serial ports.

Contents

1 Introduction	4
2 Operation	4
2-1 Turn on and off	4
2-2 Basic operation	4
2-3 Alarms	5
2-4 Simulate mode	5
2-5 Key reference	5
3 Depth, keel offset, too deep alarm, too shallow alarm	6
3-1 Set depth units	6
3-2 Set too deep alarm	6
3-3 Set too shallow alarm	6
3-4 Anchor watch	7
3-5 Set keel offset	7
4 Systems of several instruments	7
4-1 NavBus	7
5 Explorer D310 hardware	8
5-1 What comes with your Explorer D310	8
5-2 Other parts required	8
5-3 Transducer	8
5-4 Accessories	8
6 Installation and setup	9
6-1 Installation	9
6-2 Set up	10
6-3 Resetting to factory defaults	10
Appendix A - Specifications	11
Appendix B - Troubleshooting	11

Units

The factory default units are metres. To change these units, please refer to section 3-1 of this manual.

1 Introduction

The Explorer D310 measures and displays the depth of the water. An installed Explorer D310 usually has two parts:

- The display unit.
- A depth transducer, which is attached to the hull and wired to the display unit.

The unit is powered from the boat's power supply.

The Explorer D310 is part of the Northstar family of instruments for boats, which includes instruments for speed, depth, wind and repeaters. These instruments can be connected together to form an integrated data system for a boat (see section 4).

For maximum benefit, please read this manual carefully before installation and use.

How the transducer measures depth

The depth transducer generates an ultrasonic (sound) pulse, which travels down through the

water. When the pulse meets the bottom, some of the pulse is reflected back up towards the boat and is received by the transducer.

The display unit analyses the reflections from each pulse. It removes unwanted reflections (from bubbles and other objects) and calculates the depth by measuring the time between sending the pulse and receiving its echo.

Cleaning and maintenance

Clean the display unit and any plastic transducers with a damp cloth or mild detergent. Avoid abrasive cleaners, petrol or other solvents.

When repainting the hull, cover or remove any visible transducers. Depth transducers may be coated with a thin layer of antifouling paint; gently sand off any previous paint first.

The Explorer D310 display unit



2 Operation

2-1 Turn on and off

Turn the unit on and off with the auxiliary power switch on the boat. The unit does not have its own power switch. When you turn it off, any settings you have made are retained.

If the word SIMULATE flashes at the top, left of the display, then the unit is in simulate mode (see section 2-4).

2-2 Basic operation

The keys

The unit has four keys, labelled    and . In this manual:

- **Press** means to push the key for less than one second.
- **Hold** for two seconds means to hold the key down for two seconds or more.
- **Press one key + another key** means to push both keys together.

Set backlight for screen and keys

You can set the backlight to one of four brightness levels or off. Press once to display the current backlight level, press again to change the level:

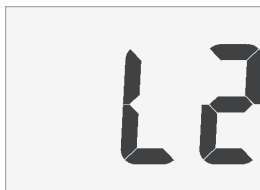

Backlight level 2

The display

The display normally shows depth. If it displays dashes (— —) then it means that the depth is too deep or unknown.

2-5 Key reference

Turn power on

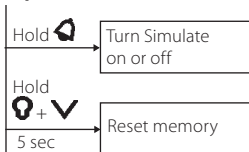

Normal operation

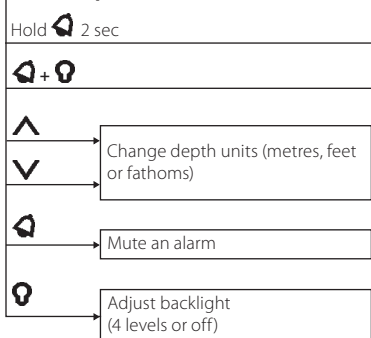

2-3 Alarms

The Explorer D310 can be set to sound an alarm when the water is too deep or too shallow (see sections 3-2 and 3-3). When the alarm sounds, the internal beeper sounds, the symbol on the display flashes and any external beepers or lights operate.

Press to mute the alarm. The alarm stays muted until the depth becomes normal. The alarm will sound if the depth becomes too deep or too shallow again.

2-4 Simulate mode

Simulate mode allows you to become familiar with the unit off the water. In Simulate mode, the Explorer D310 functions normally except the transducer is ignored and the unit generates this data internally. The word SIMULATE flashes at the top, left corner of the screen.

To turn Simulate mode on or off:

- 1 Turn the power off.
- 2 Hold down while you turn the power on.

Set alarms

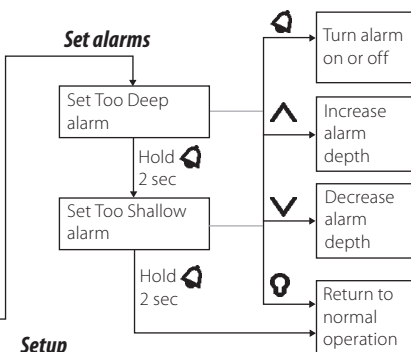

Setup

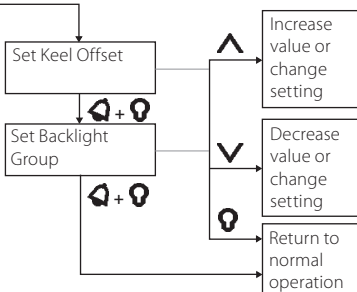

3 Depth, keel offset, too deep alarm, too shallow alarm

Depth and keel offset

The displayed depth is the distance from the transducer on the boat to the bottom of the water, plus or minus an offset which is called the keel offset:

- A **positive** keel offset displays depth as measured from a point **above** the transducer. For example, if you set the offset to the distance from the transducer to the surface, it will display

the depth from the surface to the bottom of the water.

- A **negative** keel offset displays depth as measured from a point **below** the transducer. For example, if you set the offset to minus the distance from the transducer to the bottom of the keel, it will display the depth from the bottom of the keel to the bottom of the water.

Keel offset

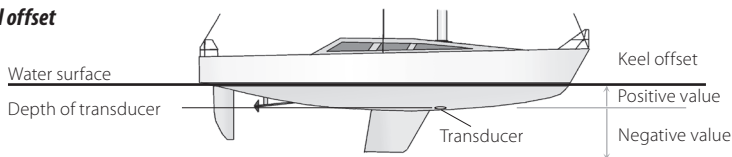

Note: The boat illustrated uses a through hull transducer

3-1 Set depth units

The units can be METERS, FEET or FATH:

- Press **▲**; if necessary, press **▲** again.

3-2 Set too deep alarm

The too deep alarm sounds if the alarm is turned on and the depth becomes equal to or more than the too deep alarm depth. To mute the alarm, press **🔇**.

To set the too deep alarm:

- 1 Hold **🔇** for two seconds to display the Too Deep Alarm screen:

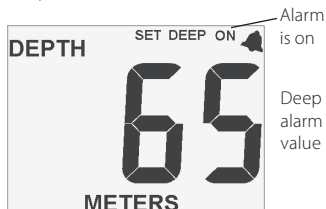

- 2 To change the alarm depth, press **▲** or **▼**.
- 3 To turn the alarm on or off, press **🔇**.
- 4 Press **🔇**.

3-3 Set too shallow alarm

The too shallow alarm sounds if the alarm is turned on and the depth becomes equal to or less than the too shallow alarm depth. To mute the alarm, press **🔇**. To set the too shallow alarm:

- 1 At the Too Deep Alarm screen, hold **🔇** for two seconds to display the Too Shallow Alarm screen:

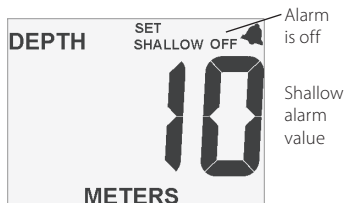

- 2 To change the alarm depth, press **▲** or **▼**.
- 3 To turn the alarm on or off, press **🔇**.
- 4 Press **🔇**.

3-4 Anchor watch

To set an anchor watch, set the too shallow alarm to slightly less than the current depth and set the too deep alarm to slightly more than the current depth. Allow for tide changes.

3-5 Set keel offset

Keel offset is described above. The range is ± 2.9 m (± 9.6 ft, ± 1.6 fathoms):

- 1 Press + to display the Keel Offset screen.
- 2 Press or to change the keel offset.
- 3 Press .



Keel offset
(negative)

4 Systems of several instruments

Several Northstar instruments can be connected together to share data. There are two ways of connecting instruments together, NavBus or NMEA.

4-1 NavBus

NavBus is a Northstar proprietary system that allows systems of multiple instruments to be built using a single set of transducers. When instruments are connected by NavBus:

- If you change the units, alarms or calibration in one instrument, then the values will automatically change in all other instruments of the same type
- Each instrument can be assigned to a group of instruments (see section 6-2, step 2). If you change the backlight in an instrument in group 1, 2, 3 or 4 then the backlight will automatically change in the other instruments in the same group. If you change the backlight in an instrument in group 0 then no other instruments are affected.
- If an alarm sounds, mute it by pressing on any instrument which can display that alarm.

NavBus and the Explorer D310

If the Explorer D310 does not have a depth transducer fitted then the unit will automatically take depth readings from another instrument, via NavBus, if the data is available. For more information, refer to the NavBus Installation and Operation manual.

Note: If a transducer is not fitted to the unit and the corresponding external data is not available then the displayed value will be dashes (— —).

4-2 NMEA

NMEA is an industry standard, but is not as flexible as NavBus as it requires dedicated connections between instruments. Depth data is output by the Explorer D310 and can be read and displayed by the Northstar Explorer R310 or other NMEA instrument.

5 Explorer D310 hardware

5-1 What comes with your Explorer D310

The Explorer D310 comes in several configurations.

Standalone configuration

- Explorer D310 unit with protective cover.
- Warranty card.
- Mounting template.
- This Installation and Operation manual.

In addition, the standalone configuration usually requires a depth transducer (see section 5-3).

Kit configuration

The Explorer D310 is available in several kit configurations with different grades of through hull transducer, with:

- The parts for the standalone configuration, listed above.
- Through hull depth transducer.
- Transducer Installation manual.

5-2 Other parts required

One or more 310 series instruments will be connected to the boat 12 V power supply via:

- An accessory switch to turn the instruments on and off.
- A fuse. Use a 1 A fuse for between one and five instruments.

Optional external beepers or lights can be fitted. The Explorer D310 output is switched to ground, 30 V DC and 250 mA maximum. If the beepers and lights require more than 250 mA, fit a relay.

For systems of several instruments, wiring and connectors are required (see section 4 or the NavBus Installation and Operation manual).

5-3 Transducer

The Explorer D310 is usually used with a through hull depth transducer. However, the unit can take readings from another instrument, in which case it may not need a transducer (see section 4).

A through hull transducer generally gives the best performance and is the best choice for displacement hulls. It is mounted in a hole drilled through the bottom of the boat.



- A plastic through hull transducer is suitable for GRP or metal hulls. Plastic through hull transducers are not suitable for solid wooden hulls (use Northstar's bronze transducers).
- A bronze transducer is suitable for wood or fibreglass hulls. Never install a bronze transducer in a metal hull, because it will cause electrolytic corrosion.

A range of Northstar through hull transducers are available, plus in hull and transom mount transducers. For more information, refer to the Transducer Installation manual or consult your Northstar dealer.

5-4 Accessories

These accessories are available from your Northstar dealer.

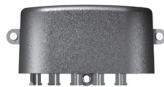

NavBus junction box
(See section 4)



4 m (13 ft) depth
transducer extension
cable

6 Installation and setup

Correct installation is critical to the performance of the unit. It is vital to read this section of the manual and the documentation that comes with the other parts before starting installation.

The Explorer D310 can:

- Drive external beepers or lights for the alarm.
- Send and receive data from other Northstar instruments connected via NavBus. Settings for alarms, units, calibration and backlighting are shared (see section 4-1).
- Send and receive NMEA data from other instruments (see section 4-2).

CAUTION

The unit is waterproof from the front. Protect the rear of the unit from water, or else water might enter the breathing hole and damage the unit. The warranty does not cover damage caused by moisture or water entering the back of the unit.

Ensure that any holes that you cut will not weaken the boat's structure. If in doubt, consult a qualified boat builder.

The choice, location, angle and installation of the transducers is the most critical part of the installation. If they are not correct, the unit can not perform at its designed potential. If in doubt, consult your Northstar dealer. Plastic through hull transducers are usually unsuitable for wood hulls. If in doubt, consult a marine surveyor or marine engineer.

6-1 Installation

Explorer D310 display unit

- 1 Choose a location for the display unit that is:
 - Easily seen and protected from damage.
 - At least 100 mm (4") from a compass and at least 500 mm (1.65 ft) from a radio or radar antenna.
 - Away from engines, fluorescent lights, and power inverters.
 - Accessible from behind; the minimum clearance required at the back is 50 mm (2") (see mounting diagram).
 - With the back of the unit protected from moisture.

- 2 The unit must mount on a flat panel which is less than 20 mm (0.75") thick. Stick the mounting template in place. Drill a 50 mm (2") fixing hole through the centre hole in the template. Note that the template allows space around the unit for the protective cover.
- 3 Remove the fixing nut from the back of the unit. Insert the stud at the back of the unit through the mounting hole. Hand tighten the fixing nut.

Transducers

- 1 If the Explorer D310 does not come with a transducer, choose a suitable transducer (see section 5-3). If the Explorer D310 is supplied with a transducer, see section 5-3 to ensure that it is suitable.
- 2 Choose a suitable location for the transducer and install it by following the instructions in the Transducer Installation manual.
- 3 Fit the cables between the transducer and the display unit:
 - Keep the cable away from other cables, engines, fluorescent lights, power inverters and radio or radar transmitters.
 - Ensure no connectors lay in the bilge.
 - If necessary, extend the cable by adding extension cables.
 - Do not cut the cable on any depth transducer.
 - Secure the cable at regular intervals.
- 4 Connect the transducer to the display unit connector.

Side view of display unit mounting

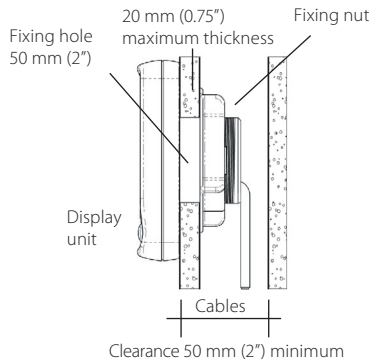

Power/data wiring

- 1 Wire the display unit power/data cable:
 - The unit requires 12 V DC power. Fit a power switch and fuse to the power supply or power the unit from a fused auxiliary switch. The fuse should be 1 A for up to five instruments.
 - If the external beepers and lights require more than 250 mA DC total, fit a relay.

A single unit can be wired as shown below:

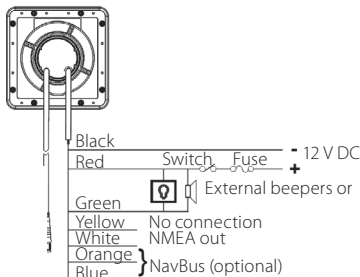

Depth

With several instruments, use the optional junction boxes to simplify wiring, as shown below:

Group 1

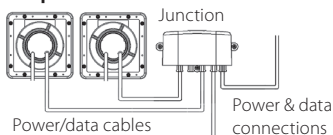

Group 2

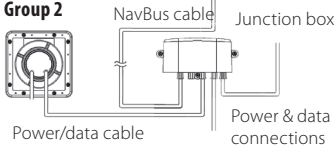

For information on how to connect NavBus and to use junction boxes, refer to the NavBus Installation and Operation manual.

- 2 Tape or cover any unused wires or connectors to protect them from water and keep them from shorting together.

6-2 Setup

- 1 Take the boat for a trial run to check that all the instruments work correctly.
- 2 If the unit is part of a system of 310 series instruments connected by NavBus, set the backlight group number (see section 4-1):
 - i Press **Q** + **Q** several times until the Backlight Group screen is displayed:



- ii Press **^** or **V** to set the backlight group number.
 - iii Press **Q**.
- 3 Set:
 - The depth units (see section 3-1).
 - The keel offset (see section 3-5).

6-3 Resetting to factory defaults

All settings may be reset to the manufacturer's default settings (see below).

To reset to factory defaults:

- 1 Turn the power off.
- 2 Hold down **Q** + **V** while you turn the power on and continue to hold the keys down for at least five seconds.

Depth units	m
Keel offset	0
Depth alarms	Off
SIMULATE mode	Off
Backlight level	0
Backlight group	1

Appendix A - Specifications

Physical

- Case size 111 mm (4.4") square.
- LCD display 82 mm (3.2") wide, 61 mm (2.4") high; twisted nematic.
- LCD digits 38 mm (1.4") high.
- Four operator keys, laser etched.
- Backlighting for display and keys, amber, four levels and off.
- Operating temperature 0 to 50°C (32 to 122°F).
- Transducer cable length 8 or 9 metres (26.25 or 29.5 ft).
- Power Cable length 1 m (3.25 ft).

Electrical

- Power supply 10.5 to 16.5 V DC, 30 mA without backlighting, 190 mA with full backlighting and transducer.
- External beeper or light output, switched to ground, 30 V DC and 250 mA maximum.

Depth

- Range 0.5 to 130 m (1.5 to 400 ft, 0.3 to 67 fa).
- Typical accuracy < 2% (depends on type of depth transducer, installation and water clarity).
- Displays 0.0 to 19.9, 20 up.
- Adjustable keel offset ± 2.9 m (± 9.6 ft, ± 1.6 fa).
- Too deep and too shallow alarms (run both at once to provide anchor watch facility).

Interfaces

- NavBus connection to other Northstar instruments.
- NMEA 0183 outputs: DBT, DPT, PTTKD.

Standards compliance

- **EMC compliance**
 - **USA** (FCC): Part 15 Class B.
 - **Europe** (CE): EN50081-1, EN50082-1.
 - **New Zealand and Australia** (C Tick): AS-NZS 3548.
- Environment: IP66 from front when correctly mounted.

Power/data cable wires

Wire Signal

Red	Power positive, 12 V DC, 190 mA maximum
Black	Power negative, NMEA common
Green	External beeper or light out, switched to ground, 30 V DC and 250 mA max.
Orange	NavBus +
Blue	NavBus -
White	NMEA out
Yellow	No connection

Appendix B - Troubleshooting

This troubleshooting guide assumes that you have read and understood this manual.

It is possible in many cases to solve difficulties without having to send the unit back to the manufacturer for repair. Please follow this troubleshooting section before contacting the nearest Northstar dealer.

There are no user serviceable parts. Specialized methods and testing equipment are required to ensure that the unit is reassembled correctly and is waterproof. Repairs to the unit must only be carried out by a service centre approved by Northstar. Users who service the unit themselves will void the warranty.

More information can be found on our website:

www.Northstarnav.com

1 Unit will not turn on:

- a Fuse blown or circuit breaker tripped.
- b Battery voltage is outside the range 10.5 to 16.5 V DC.
- c Power/data cable damaged.

2 Depth reading wrong or erratic:

- a Unit temporarily unable to detect bottom, for example water too deep or too shallow, water not clear, boat reversing and transducer in turbulent water.
- b Depth transducer cable unplugged or damaged.
- c Depth transducer fouled or damaged. Check for fouling, damage or too thick a layer of paint over it.
- d Depth transducer installed incorrectly or transducer does not have a smooth flow of clear water over it. Review installation.
- e Interference from the ultrasound pulse from another depth sounder.
- f Interference from electrical noise. Review installation.

To check the transducer, disconnect it and connect a known good transducer temporarily. Hold it over the side of the boat in the water and check if the unit displays a depth.

3 The word SIMULATE flashes at top, left of screen, values displayed are unexpected:

- a Unit is in simulate mode (see section 2-4).

4 The display fogs:

- a Moist air has entered the breathing tube at the rear of the unit. Air the boat or run unit with backlight fully on.
- b Water has entered the breathing tube. Return unit for service.

FOR FURTHER CONTACT DETAILS GO TO:

www.navico.com

NORTHSTAR 



Made in New Zealand
MN000626B-G
